

Myles Ginty

Automotive & Motorsport Engineer

Thornhill Court, London rd

Headington, Oxfordshire

07368598425

myles.ginty@gmail.com

MSc Dissertation (Distinction) - Fluid Structure Interaction on a Formula Student Front Wing

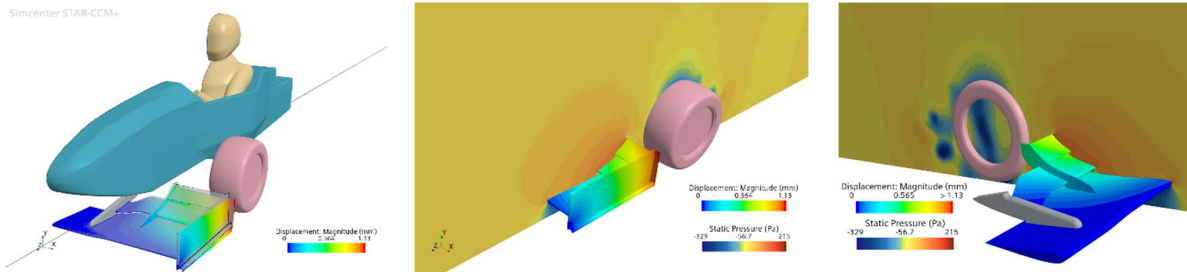

This Dissertation involved taking the established design for the Oxford Brookes Racing 2025 Front wing and validating it in a fluid-structure interaction simulation, which simulates the Stress analysis and Fluid Flow simultaneously to provide instant feedback and the change of the front wing while illustrating the impact on the aerodynamics.

Oxford Brookes Racing Formula Student 2025 – Front wing with Enlarged Endplate curvature & Front Motor Cooling Duct

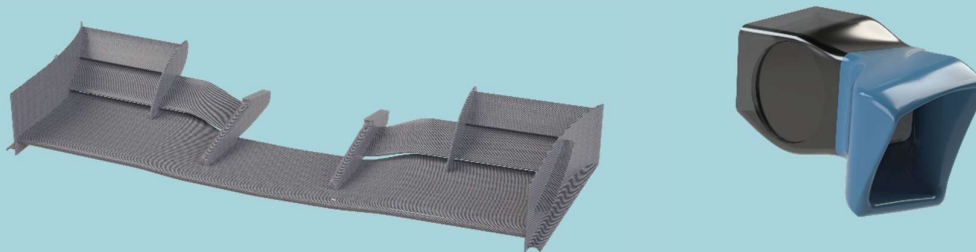

First is the front wing planned for this years package with an enlarged endplate design iteration to reduce disruptive flow to devices behind. Second is the front air-cooled ducting inlet for the unsprung motors, aimed at directing more flow from the angled front wing to the heatsink inside the cover.

Oxford Brookes Racing Formula Student 2025 – Front Wing Team 3 Design Iteration 1.5



This Front wing update was added to simulate the effect of the flow with the mounts and simplify the overall assembly with the new design target to maintain aero balance. This simplification was also, as a result of the 1.4 iteration which shows a loss in performance with curved cascade flaps.

Oxford Brookes Racing Formula Student 2025 - Aero Package Team 3 Design Iteration 1.4

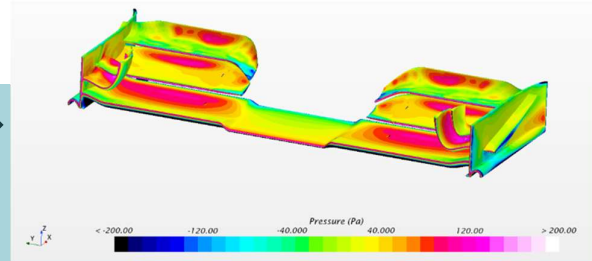
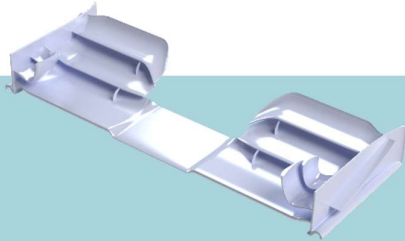
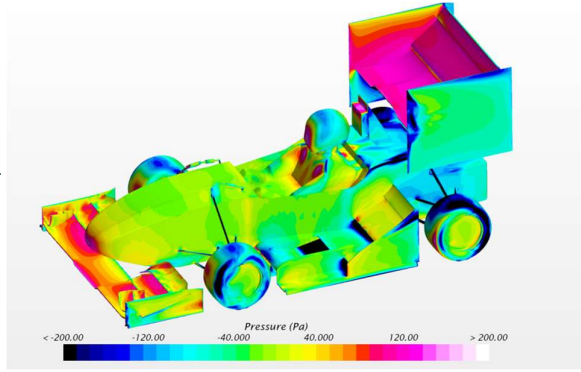
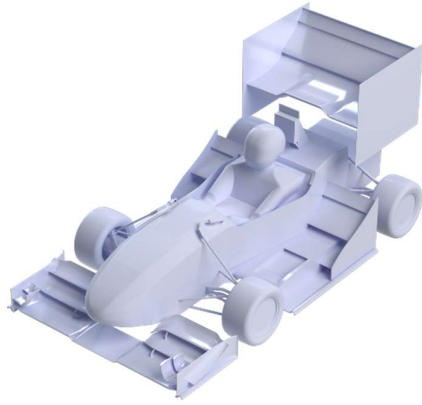

The Design team, which I coordinated, was set up to develop a design to remove the previous sidepod design and incorporate the same radiators into the side wing venturi. Along with the new side wing design, another one of the responsibilities was to design and validate a new front wing.

Formula Student - Composite Anti-Intrusion Plate Assembly 2024

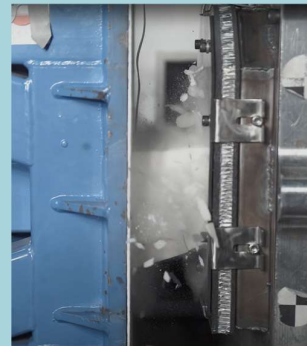
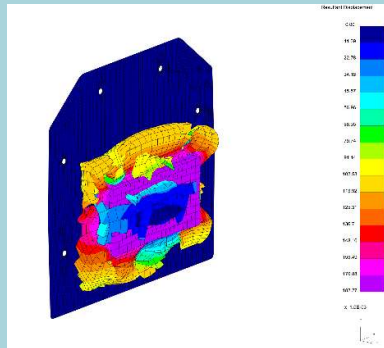
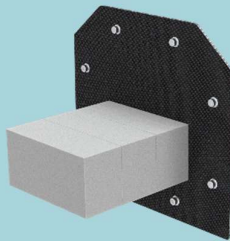

Involvement with Composites included the responsibility of implementing a composite anti-intrusion panel with testing done with Cranfield University Impact Centre.

Oxford Brookes University MSc Motorsports Engineering – Composite Design

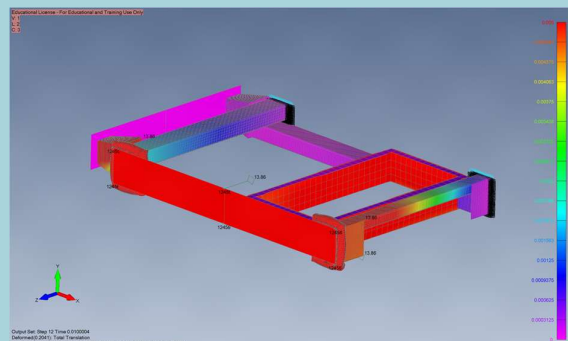
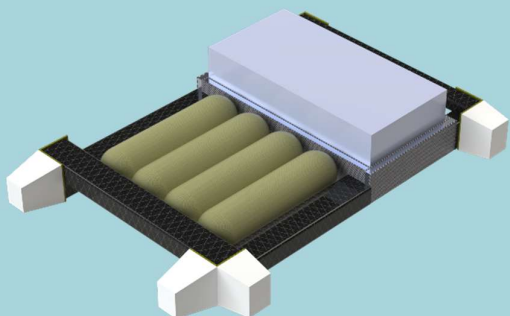

One of the coursework designs I have modelled was to create a FCEV composite chassis and have it simulated in Siemens Femap. Performing both front and side impact where made to test not only the durability of the design but also the effectiveness of the added attenuators.

Oxford Brookes Racing Formula Student 2024 - Aero Package Team 1 Design Iteration 2.4

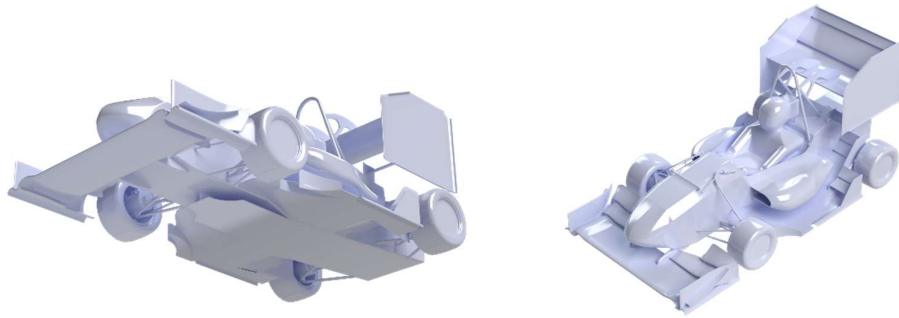

As coordinator for the design phase of the 2024 Aero subsection, this design was focused on implementing a simplistic, manufacturable venturi with existing wing elements. Utilising as much of the existing elements from previous years, culminating in an all-new aero package.

Oxford Brookes Racing Formula Student – Final Aero Package 2024



As a coordinator, I assisted with not only incorporating the successful aspects of design 2.4 to the final iteration but also the delivery of bringing the final design iteration into circulation with the PLM and maintaining the drafts of the various bodywork and wings with their accompanying moulds.

Oxford Brookes Racing Formula Student – Manufacturing Design 2024

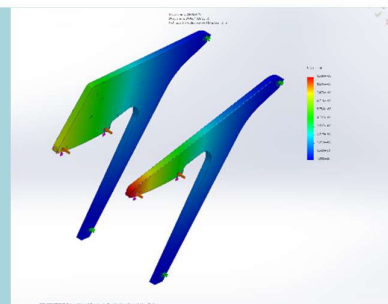
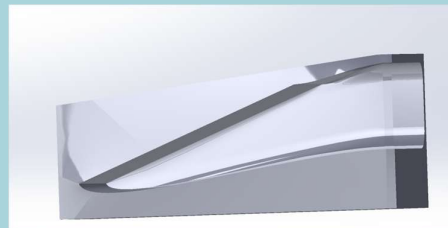
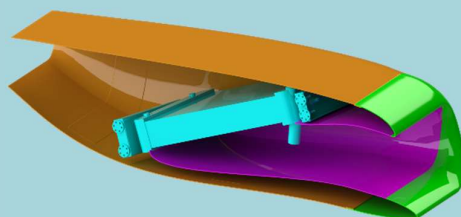
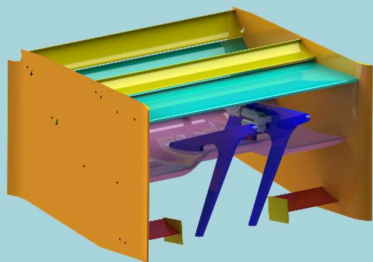

The Manufacturing aspect of the role I had at Oxford Brookes Racing included the design of some of the moulds used to construct the final product such as the duct mould. Also the validation required for the selected composite configuration.

FSAE Ontario Tech Racing - Aero package 2020 – 2021

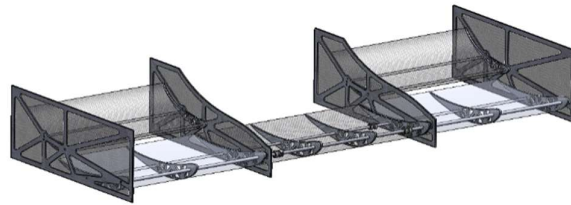

As Aerodynamics Department leader for 2020 and 2021 year cars an Aero package was developed employing new manufacturing techniques and automated validation for airfoil designs.

FSAE OTR Composite Monocoque 2021

The final year project of Undergrad was designing a Carbon fiber Monocoque chassis for the FSAE university team to migrate away from a steel tube frame chassis.

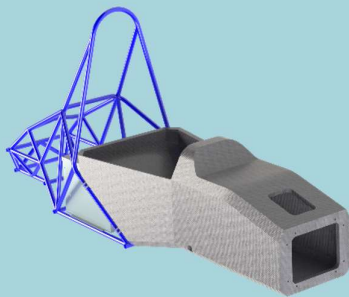

In Wheel Electric motor Test platform 2019

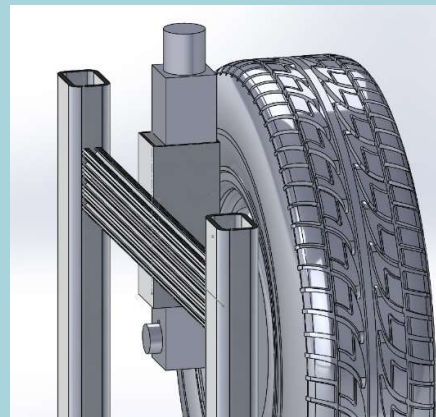

Above is the electric wheel testing platform design. A NSERC Research project to construct a platform for testing OEM in wheel electric motors performance parameters.